



Internal Rope Halyard flagpole categories contain multiple Flagpole Truck options. Your flagpole will contain one of the trucks shown below.

Internal Wire Halyard Revolving Truck



Internal Wire Halyard Single Revolving Ball Truck



WARNING: Do not install flagpole near overhead power lines. Always be aware of cable and pipes buried underground. Utility departments should be contacted to confirm that it is safe to dig in the area where flagpole is to be installed. It is advisable to have assistance with flagpole installations. Any flagpole with a 5" diameter base or larger or over 25' in length may require lifting device. Following review of instructions, the purchaser of the flagpole should determine if they are qualified to perform installation or they should obtain the services of a professional sign/flagpole installation company. Due to various methods of installation used by installers, Concord American Flagpole cannot be liable for structural damage or injury occurring during flagpole assembly and installation.

Section 1. Foundation Installation

Prepare the foundation hole for Ground Sleeve or Shoe Base installations as detailed in following instructions. NAAMM's **Metal Flagpole Manual** offers basic suggestions on foundation requirements in firm, dry soil using dry tamped sand and 3000 PSI concrete (See Page 6).

NOTE: Soil conditions vary by site and the listed dimensions are considered minimum dimensions for foundations in firm dry soil.

Exact foundation requirements should be verified by a Structural Engineer with knowledge of soil conditions in your area.

Flagpole Ground Sleeves are available in either PVC or Corrugated Steel with Steel Lighting Spike and Setting Plate (**PART I**). Refer to diagrams on Page 6 for foundation illustrations.

1A. Corrugated Steel with Steel Lighting Spike and Setting Plate

Set ground sleeve in center of hole, pushing corrugated sleeve rod into the ground until ground sleeve steel support plate is resting on the bottom of the hole. The top of the sleeve should be 2" above grade. When concrete is poured, it will fill in the area between the setting plate and the base plate. Carefully plumb the ground sleeve tube vertically and brace it so that it cannot move while concrete is being poured. Use a level inserted into the sleeve to ensure it is vertical.

Slowly pour concrete, continuing to verify vertical plumb. Care should be taken that the pouring of the concrete is not at a rate that might cause the ground sleeve to "float up" as the concrete goes under the base plate (refer to drawing). Trowel to desired finish. Keep the inside of the sleeve dry and free of debris by covering the opening. Allow concrete to cure for a *minimum* of 24 hours.

1B. Shoe Base Foundation

All Concord American Flagpole Shoe Base Flagpoles include steel Anchor Bolts and stainless steel attaching hardware. Full size, 1:1 mounting templates with full instructions are shipped with the hardware.

Section 2. Shaft Preparation

Flagpole should be assembled with base as close as possible to final installation location. Flagpole shaft configuration can be either 1-Piece or Multi-Piece.

2A. 1-Piece Flagpoles

Place flagpole shaft on sawhorses in order to attach components. Proceed to Section 3.

2B. Multi-Section Flagpole

Multiple section flagpoles are designed and fabricated with self-aligning jam sleeve for each flagpole joint. Joints incorporate tight tolerances for a strong and permanent field assembly. Inspect shaft sections for damage before any assembly.

NOTE: Disassembly of shaft sections, after assembly, without damage is extremely difficult or impossible. No hardware should be installed until shaft sections are completely assembled. The following information is intended to be a helpful guide to the installer.



start with bottom sections. Sections must be straight and level while sliding together.

NOTE: All multi-piece joints are custom fit from factory. Once fit, each section is stamped with both aligning match marks and corresponding numbers. Before proceeding, verify that the numbers are the same. If they do not match **DO NOT PROCEED**, as sections will not properly

Carefully lay flagpole sections out in proper order. Set bottom section on blocks, saw horses, or short pieces of larger diameter PVC pipe in a horizontal position with base of the lower section against an immovable object. Rotate pieces until match marks can be seen. (See Match Mark illustration) For flagpoles with 3 or more sections,

fit together. If you have purchased more than one flagpole, verify that all sections are grouped with correct matching numbers. *Sections are not interchangeable.* Carefully clean all mating surfaces outside of jam sleeve and inside bottom area of section into which the jam sleeve will be fitted. Inspect and remove debris or burrs.

Cover jam sleeve and inner area of section that it will be going in to with a light layer of liquid soap.

Keep finished shaft surface free from hand prints and excess lubricants. Gently slide sections of flagpole, with match marks in line with lower section, onto jam sleeve as far as possible without forcing the two pieces together. Rolling flagpole 180° with every 2" to 3" may facilitate easier fit. If extreme difficulty is experienced while fitting the first 6 inches together, pull apart and cool the male section with ice for several minutes. With pieces in line, place a 4x4 block of wood against top of flagpole, to absorb direct shock, and firmly strike wood to drive the sections together. Excessive force is not necessary. If pieces are not coming together, contact your dealer. If flagpole is a 3-piece unit, clean, lubricate and install the next section in same manner as above.

Section 3. Hardware Assembly

When working with threaded aluminum components, a light coat of an anti-seize compound (available at most hardware stores) is recommended.

3A. Ornament Assembly

Remove top half of Truck or Ball Truck (**PART B**). It is not necessary to undo pre-strung cable assembly. Unpack flagpole ball, eagle or finial (**PART A**) and thread jam nut completely up threads. An epoxy (Loc-Tite type product... by others) is recommended. After applying a small amount of epoxy, carefully thread ball into top of truck. Be careful not to cross thread the components. Grip spindle/rod with vise grips and tighten. Do not grip ball to tighten. Ornament shaft should protrude approximately 1/4" inside the truck cover. After ball is in place, snug jam nut against top of truck assembly. If truck incorporates a set screw, use Allen wrench to tighten screw into Ball Stem. Optional eagles and finials are attached in the same manner. Consideration must be given to the direction that you want the eagle or finial to face. Eagles should face in the same direction as the flag. Reinstall top half of truck ensuring that center pulley aligns with center of spindle.

3B. Cable Assembly

Uncoil cable assembly that extends through spindle of truck. Carefully feed cable through pole until cable can be seen through door opening. The swivel incorporated into the cable fits inside the shaft and is a very important component in the operation of the cable. Pull end of cable through door opening and tape to outside of pole.

3C. Truck Assembly

Internal Halyard Trucks (**PART B**) are available in Revolving Truck and Ball Truck options. Both are designed with 1-1/4" NPT spindles which are inserted into a threaded insert welded into the top of the flagpole.

Carefully check for burrs or irregularities on the threads of the Rotating Truck Assembly and the threaded insert in the top of the flagpole shaft. After feeding the halyard through the pole and installing the ball, eagle, or finial, carefully thread the spindle of the Rotating Truck Assembly into the top of the flagpole. Do not use epoxy on the spindle of the truck. Extreme care should be taken to avoid cross threading the components, as aluminum threads can be easily damaged. Snug the spindle using an appropriate sized wrench. The threads are tapered and are manufactured in such a manner that over half of the spindle threads should go into the shaft before it is fully seated. If damage occurs during this process, contact your dealer.

3D. Winch Assembly

The Winch Assembly is installed into the flagpole at the factory. To attach the wire halyard to the winch, remove the screw located on the center shaft of the winch. Bring the cable behind, under, and up in front of the winch. Place the copper cable stop located at the end of the wire halyard into the slot in the center shaft. Ensure that the stop is seated firmly and straight. Reinsert the screw into the center shaft over top of the copper cable stop and tighten.

3E. Collar

Before standing flagpole, gently slide the flash collar (**PART H**) up from bottom and tape it out of the way near the cleat. The use of protective wrapping around the shaft at this location will provide protection to the finish during the installation process.

Section 4. Standing The Flagpole

The flagpole should be moved to a position that places the base of the flagpole close

INSTALLATION INSTRUCTIONS

INTERNAL WIRE HALYARD WINCH FLAGPOLE

- Titan (IWW)
- Sovereignty (ISW)
- Independence (IRW)
- Xtreme (XIWW / XIRW)
- APEX (AIRW)

Read these instructions completely before any installation is started. Pay close attention to all safety concerns. In the unlikely event that you encounter any difficulty, or if a part is missing from the parts diagram, please contact the dealer or representative from which the flagpole was purchased.

Inspection of the Shaft and Components

Inspection of the shaft for shipping damage should be done at the time of receipt. Flagpole packaging is carefully chosen to protect the finish during transportation. Any tear in the package should be inspected for possible damage. If the flagpole is delivered showing signs of freight damage, shipment should be refused. Dealer or representative from which the flagpole was purchased should be immediately contacted. Verify that all standard or substituted parts have been received in acceptable condition. If there is any damage to the shaft or components, do not continue with the installation without first contacting the dealer. To continue with the installation signifies the acceptance of the product in the condition received. Concord American Flagpole will not be responsible for later installation expenses for missing or damaged parts.

WARNING:

NOTE: To prevent staining, the flagpole must be stored in a dry place OR all packaging must be removed immediately after receiving shipment. If the flagpole gets wet with the packaging still on it, the flagpole may develop stains as it dries. Once packaging is removed, the flagpole should be stored off the ground on blocks until installation.



to the foundation. Stand flagpole into previously installed ground sleeve (Ground Set Installation) or onto anchor bolts (Shoe Base Installation). This may require the use of a crane or backhoe for larger flagpoles. Professionals experienced in such installations should perform rigging and lifting. During lift, keep clear of the area and reach of the flagpole path. Do not pass flagpole overhead.

Multiple-Piece Flagpoles - When installing multi-piece flagpoles, extra care must be used when setting it into the sleeve. Before standing the flagpole, make certain that the joints are fully seated and that the shaft is straight. Never stand a flagpole that is not properly assembled and straight. Arrange the rigging for the lift in such a way that weight of the flagpole sections is supported from the bottom of the flagpoles so that the flagpole joints are pushed together, not pulled apart, during the lift. Keep clear of power lines.

NOTE: The flagpole joint IS NOT designed to support the weight of the bottom or middle section of the flagpole when raising a multi-sectional flagpole. ALWAYS CHOKE A MULTIPLE SECTION FLAGPOLE BELOW THE LOWEST JOINT AS A SAFETY PRECAUTION.

4A. Ground Set

On flagpoles with spacing between the shaft and the inside of the setting tube, insert flagpole into ground sleeve (galvanized corrugated 16-gauge steel) and plumb flagpole with wooden wedges (by others). Slowly fill the void between the flagpole and the ground sleeve with washed and screened dry tamped sand. Do not use silica sand. Fill ground sleeve 6" to 8" at a time and tamp as you fill. Fill ground sleeve with sand to about 2" from top, then cap off with waterproof compound (by others). Refer to NAAMM's **Metal Flagpole Manual** illustration (See Page 6).

4B. Shoe Base

After placing the flagpole on top of the anchor bolts, install flat washer, lock washer, and hex nut. Tighten nut and verify that all threads are fully engaged. Refer to full installation instructions located on Bolt Circle Template shipped with the anchor bolts. **NOTE: An installation using "double nuts" is not recommended by Concord American Flagpole.**

4C. Finishing The Installation

After waterproof compound has dried (Ground Set Installations) or the nuts have

been tightened (Shoe Base Installations), slide flash collar (PART H) down into position and caulk joint with matching color silicone to seal the space between the flagpole and the flash collar.

Section 5. Halyard Components Assembly

Use the top link of the Flag Arrangement Assembly (PART C) to attach the assembly to the swivel at the end of the wire cable assembly. At the opposite end of the flag arrangement, attach the counterweight (PART E) to the bottom link of the Flag Arrangement Assembly. Wrap the Retainer Ring Assembly (PART F) around the pole and attach to the opposite end of the counterweight using a provided Stainless-Steel Connecting Link (PART D). Reference the diagram on Page 5.

SAFETY NOTE: The Retainer Ring and Flag Arrangement should never be attached to the same end of the counterweight.

Using the winch handle (PART G), raise the assembly off of the ground. Attach the flag to the flagsnaps and raise the flag to the desired height.

SAFETY NOTE: When raising or lowering the flag assembly be cautious as clothing, equipment, etc. can easily become tangled in the winch, causing damage and / or injury.

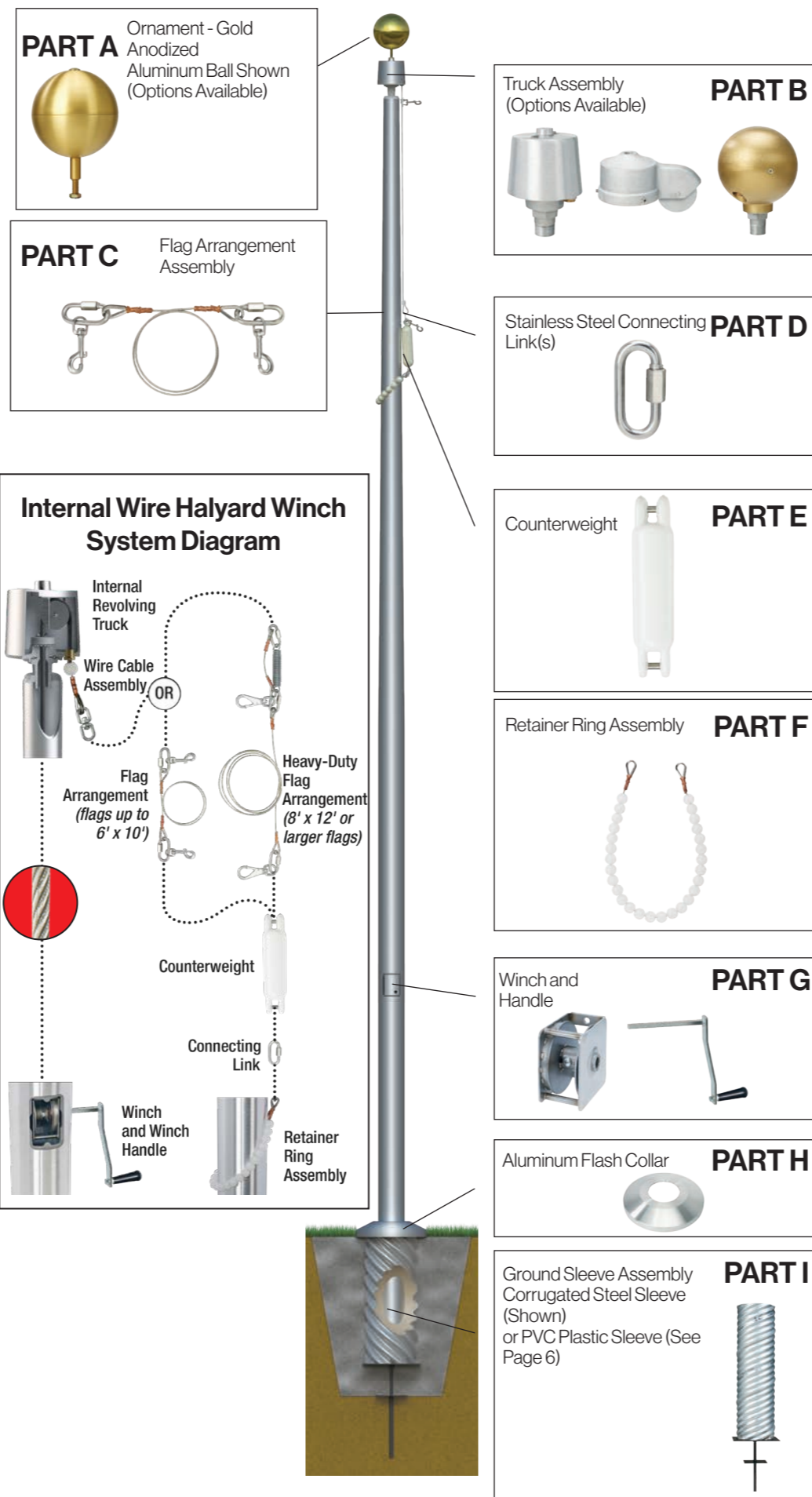

FOUNDATION INSTALLATIONS

NAAMM's **Metal Flagpole Manual** offers basic suggestions on foundation measurements in firm, dry soil only using dry tamped sand and 3000 PSI concrete. These dimensions should be considered as minimum recommendations as soil conditions vary by site.

Exact foundation requirements should be verified by a Structural Engineer with knowledge of soil conditions in your locality.

GROUND SLEEVE INSTALLATION

NAAMM Minimum Recommended Foundation Measurements (Structural Engineering Requirements for Foundations Verified By Others.)

Ground Sleeve with Steel Lighting Spike Installation

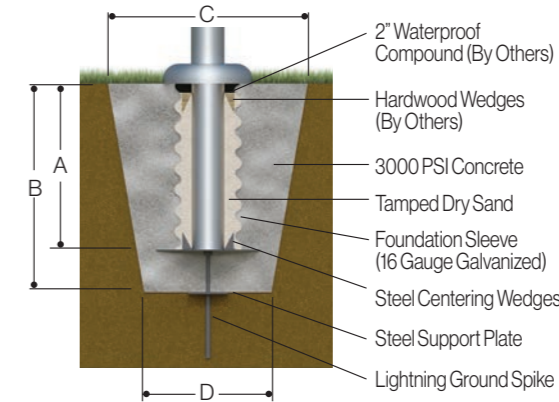

EXPOSED MOUNTING HEIGHT	Ground Set			
	A	B	C	D
20'-0"	2'-0"	2'-6"	30"	24"
25'-0"	2'-6"	3'-0"	36"	24"
30'-0"	3'-0"	3'-6"	36"	24"
35'-0"	3'-6"	4'-0"	36"	30"
40'-0"	4'-0"	4'-6"	45"	36"
45'-0"	4'-6"	5'-0"	45"	36"
50'-0"	5'-0"	5'-6"	50"	42"
60'-0"	6'-0"	6'-6"	60"	48"
70'-0"	7'-0"	7'-6"	60"	48"
80'-0"	8'-0"	8'-6"	72"	48"

PVC Ground Sleeve Installation

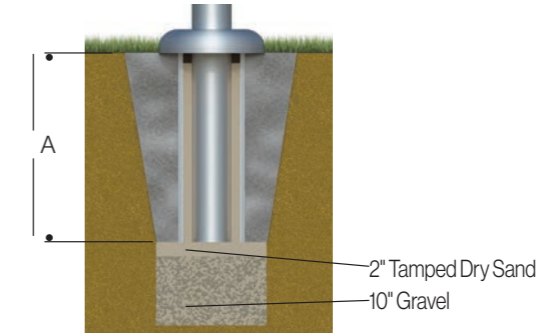

SHOE BASE FOUNDATION

(Structural Engineering Requirements For Foundations Provided By Others.)

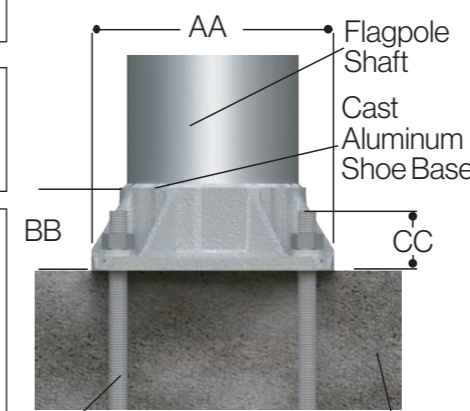

BUTT DIAMETER	Shoe Base				
	AA BASE SQUARE	BB BASE HEIGHT	CC BOLT PROJECTION	BOLT DIAMETER	BOLT CIRCLE DIAMETER
4"	7-1/2"	3"	2"	3/4"	6-1/2" - 8"
5"	7-1/2"	3"	2"	3/4"	7-1/2" - 8"
6"	9-3/4"	3-1/2"	2-3/4"	1"	9"-10"
7"	10-1/2"	3-11/16"	2-3/4"	1"	10"-11"
8"	11-1/4"	3-15/16"	2-3/4"	1"	11"-12"
10"	14"	4-7/8"	3-1/4"	1"	14"-15"
12"	17"	8"	3-3/4"	1-1/4"	16"-18"

Four galvanized Steel Anchor Bolts (55,000 PSI Minimum Yield). 3000 PSI Concrete

Shoe Base Foundation Installation

